



UTEX INDUSTRIES, INC.

UTEX INDUSTRIES, INC. CORE-X® PLUNGERS

PROVEN PERFORMANCE



Reduce Downtime and Lower your Total Cost of Ownership with Certified Core-X® Quality.

Utex Mansfield is the Exclusive Manufacturer of the Core-X® Plunger and Core-X® line of products. Our high performance plungers are designed to exceed industry standards while delivering robust cost savings and reduce your total cost of operations.

Features and Benefits:

Superior Wear Resistance

In test after independent test, our plungers consistently out-perform market-leading competitors by massive margins. Our thermal spray process hard-faces our plungers with nickel-chromium based alloys, providing an excellent abrasion and corrosion resistant surface. We can also customize surface conditions to meet your application's specific needs.

Incredible Material Properties and Custom Specs and Sizes

Our Core-X® Plungers don't just meet OEM materials and sizes, it will exceed them. Just our standard Core-X® Nickel Plunger alone has 35% more hardness (BHN) than a competitive 1018 plunger.

Certified Core-X® Quality

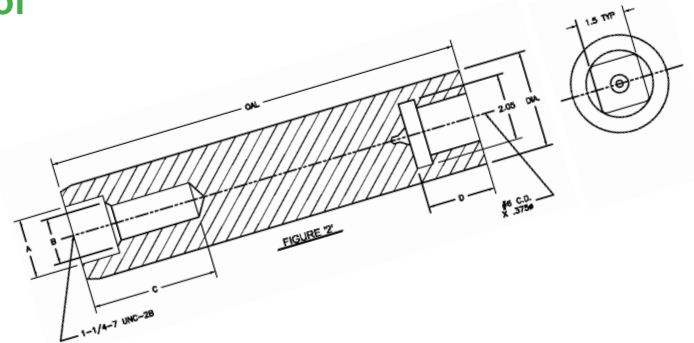

We Support ALL Major Pump Manufactures in Standard NiCr Blends, Tungsten Blends, and Custom Blends

SPM, Gardner Denver, MSI, Axon/Demay, CAT, Forum, and more.

Tremendous Cost Savings

Equipment failure in the oil and gas industry can be disastrous. Our Core-X® Plungers have a significantly longer life span which means less maintenance and minimal downtime.

Re-Fusion

Looking to save even more money? Respray your existing plungers! Reach out to your local sales representative for more information.

Utex Mansfield
102 Sentry Drive
Mansfield, TX 76063

www.utexind.com

© 2018 UTEX INDUSTRIES, INC. ALL RIGHTS RESERVED.